

# REVOLV BELT COATERS

## THE ADVANTAGE

Your confectionery coated products will have the eye appeal that makes candy lovers take a second look. Our coater delivers **uniform coating** of chocolate - milk, dark, and white - and yogurt to perfection.

## COMPLETE SOLUTION

Candy Worx offers custom solutions from single to multiple machine systems, including piping, process tanks, infeed and discharge conveyors, pumping, and complete automation.

## APPLICATIONS

Nuts  
Raisins  
Dried Fruit  
Coffee Beans  
Pretzel Chunks

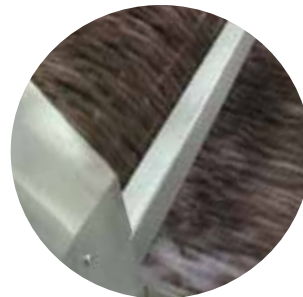

SAVE TIME, LABOR, &  
COST OF OPERATION



CONSTRUCTED FOR  
COMPLETE WASH DOWN



SMALLER FOOTPRINT THAN  
INDUSTRY STANDARDS



MADE IN THE USA

Candy Worx, A SPEC Brand

25523 W. Ruff St. Plainfield, IL 60585 | P: 815.676.5006 | [www.candy-worx.com](http://www.candy-worx.com)

# PRODUCT SPECIFICATIONS

Machine Size Belt Coater (in)	Approx. Capacity (lbs)	Approx. Capacity (kg)	Approx. Volume (cubic feet)	Approx. Volume (m <sup>3</sup> )	Standard Machine Footprint L x W x H (in)	Standard Machine Footprint L x W x H (mm)
18	35	16	1	.03	28 x 24 x 28	711 x 609 x 711
36	125	57	3	.09	49 x 52 x 72	1244 x 1320 x 1828
48	325	147	9	.25	68 x 80 x 86	1727 x 2032 x 2184
60	475	215	12	.34	80 x 80 x 86	2032 x 2032 x 2184
72	625	283	15	.43	92 x 80 x 86	2336 x 2032 x 2184

## FEATURES

Open-architecture and tubular stainless steel design facilitate internal system wash down to reduce cleaning time.

Clean without removing belt, even to allergen-free standards

FDA compliant material: sidewheels, plastic, and belt

Recipe-driven controls with on-the-fly editing keeps production moving

Easy, one-touch electronic calibration, calculates and displays weight after each coating automatically

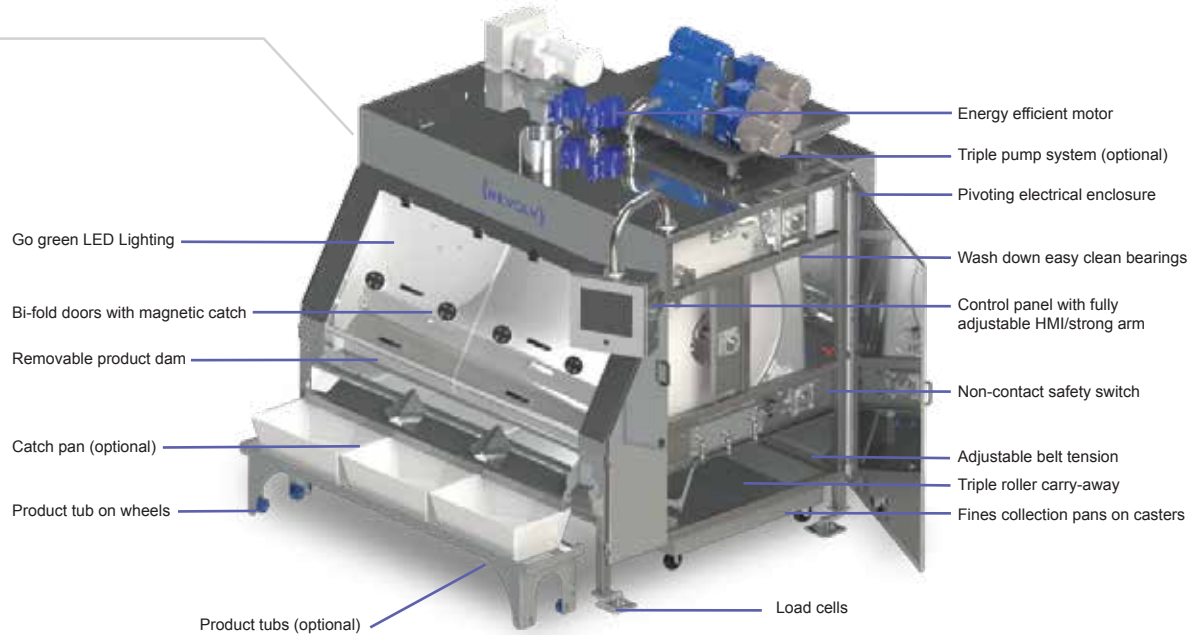

## FEATURES

Turns chocolate flow on/off, PD pump option available

Reclaims chocolate to reduce product loss, cleaning time

Melt tank keeps large quantities of chocolate heated, fluid and in constant motion for feeding to coating and enrobing machines (250 - 10,000 lb. capacity)

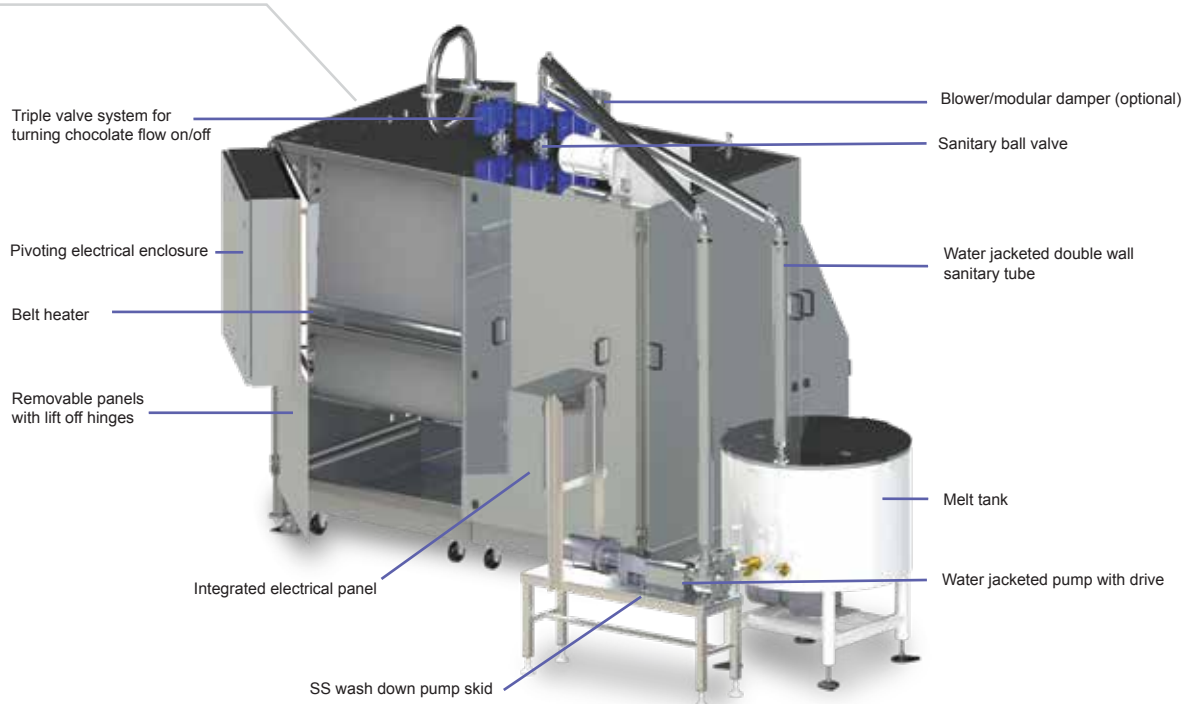

MADE IN THE USA

Candy Worx, A SPEC Brand  
 25523 W. Ruff St. Plainfield, IL 60585 | P: 815.676.5006 | www.candy-worx.com